

DESIGN OF A PROTOTYPE OF PAPERMONEY DETECTOR FOR THE VIEW

Nurfitria Khoirunnisa¹, Fauzan Akbar², Dinda Nur Hasanah³, Haryati⁴
^{1,2,3,4}Department of Information Systems, Politeknik Negeri Subang, Indonesia

Article Info

Article history:

Received Jun 15, 23

Revised Jun 19, 23

Accepted Jun 23, 23

Keywords:

Agile Development,

Arduino UNO,

Black Box Testing.

ABSTRACT

To access resources and information, use the library. The issue is that some libraries do not yet have a web-based online system for locating learning resources. Due to their inability to recognize and see money, blind persons are more likely to swap, misappropriate, or even defraud money during buying and selling operations. Designing a "Prototype of Banknote Nominal Detector for Blind People" and creating a "Prototype of Information System Data Presentation of Banknote Detector for Blind People" are the main goals of this study. This system's design adheres to the agile software development process. The rupiah money can be identified by the prototype of the nominal banknote detector based on the nominal entered; the accuracy value is 93% for banknotes in neat conditions, 87% in wrinkled conditions, 71% in wet conditions, and 53% in faded color conditions. And the development of a data presentation system in the form of a dashboard can help admins in managing data from testing activities more easily, and so that data can be stored more systematically.

Corresponding Author:

Nurfitria Khoirunnisa,

Information System Department, Subang State Polytechnic.

JL Brigadier General Katamso No. 37, Dangdeur, Kab. Subang, West Java, Indonesia

E-mail: nurfitria@polsub.ac.id

1. INTRODUCTION

The dissemination of information to the general public is now accomplished effectively and efficiently through the use of information and communication technologies. Even while knowledge, in addition to clothing, food, and shelter, is one of the basic needs, we may quickly access a variety of technological advancements. Long-distance communication, information gathering, and human labour are all made easier by the use of information technology. Today, information technology applications are used in almost all organizational functions.[1] Information technology can be defined as a combination of computer and telecommunications technology with other technologies such as hardware, software, databases, network technology and other telecommunications equipment.[2]Furthermore, information technology is used in organizational information systems to provide information for users in the framework of decision-making.

The eye is the sense of sight which functions to see the shape, size, color, and position of an object [1]. To see colors through the spectrum, the eye must have the ability to accurately distinguish the basic colors, namely Red, Green, Blue (RGB). According to the 1993-1996 audiovisual survey, the blindness rate in Indonesia was 1.5%, the highest in Asia, 1% in Bangladesh, 0.7% in India and 0.3% in Thailand. That is, if 12 people go blind every hour in the world, and 4 of them come from Southeast Asia, then 1 person is certain to

come from Indonesia. The weakness of the blind in identifying money can cause money to be exchanged, mistaken, or even deceived during buying and selling activities [2].

In a previous study by Ikhsan and Putri Permata Sari entitled "Arduino-Based Nominal and Authenticity of Rupiah Banknote Detection System for the Blind," this study discussed the design of a tool to help the visually impaired recognize rupiah banknotes by utilizing the RGB color range pattern. Output issued in the form of sound and writing on the LCD.

The purpose of this research was to build a prototype of a banknote nominal detection tool as a test material for the concepts that have been described so that they can be implemented or circulated optimally to people with visual impairments and to build an information system for presenting data from prototypes that have been built so that data can be processed and stored systematically. .

2. METHODS

The type of research used is literature study, which is a research method that is carried out by collecting, reading, and processing data from related documents.

The scope of the research framework is as follows:

1. Preliminary survey

Make observations about the condition of the research environment by viewing or reading the news. From the results of observations it is known that it is difficult for the blind to recognize banknotes.

2. Literature review

Literature study contains references and theories needed to complete the research. Sources in research come from articles, internet sites, news related to research problems. In this case the problem is more focused on blind people who have difficulty recognizing rupiah paper currency.

3. Formulation of the problem

Formulation of the problem is a very important step, because this step will determine where a research will be directed. The formulation of the problem is essentially the formulation of questions whose answers will be sought through research. The formulation of the problem in this study is as follows:

- a. How to help blind people know the nominal value of banknotes.
- b. How does the prototype read nominal on rupiah banknotes.
- c. How can the presentation of data from testing prototypes of banknote nominal detectors be stored systematically?

4. Research purposes

Research objectives are needed to answer existing problems. So this study aims to help the visually impaired in recognizing the rupiah currency, especially banknotes.

5. Data collection

At the data collection stage, the required data is grouped into two, namely:

a. Primary data

Data obtained by collecting documents related to the manufacture of banknote nominal detection devices using Arduino.

b. Secondary Data

The secondary data obtained is regarding data related to the need for tools to make prototypes as well as details of the time of research implementation.

6. Results and Discussion

For further data the results of data processing are analyzed, where the analysis aims to study existing problems and draw conclusions from these problems.

7. Conclusions and recommendations

From the results that have been obtained and analyzed, the conclusions and suggestions given can be used as input to the research implementers and those in need.

2.1 System Analysis

System analysis is the process of figuring out the specifics of what (instead of how) a given system will accomplish. To improve already-existing systems or solve unresolved issues, system analysis steps are being conducted. The web is a collection of pages that show different types of static and dynamic text, data, photos, videos, and/or a combination of all of these.[3]The web is a method for presenting text, images, multimedia, and other content on the internet network. It is connected to documents.[4]

2.2 Agile Software Development

Is one model that describes Software Quality Factor or software quality. Agile software development is a software expansion method that is based on the same rules or system development in a short time by prioritizing fast interaction from development to differences that occur in any form. The stages used in the Agile Method are planning, implementation, testing, documentation, deployment and maintenance.[5]

a. System planning is one of the initial stages in the categorization process which requires a step or stage.



Figures 1 Agile Method

At this stage the developer and user make a design based on mutual agreement. Activities carried out in the form of interviews, observations and viewing existing document archives.

- b. Implementation, namely menu preparation for customers which results from the design of a new system that is approved in the programming language. In this step, coding and web design are carried out.
- c. Testing / testing, is the main prerequisite of a system. In this step the developer develops the system in the form of coding, then tests the new software. The system that has been implemented will be tested so that there are no errors or bugs when the system is running.
- d. Documentation is the process of documenting a device, done by recording the system being built step by step. In this step, test results are documented to facilitate future maintenance.

- e. Deployment, the developer disseminates information about service updates to customers. At this step, testing of the system is carried out again with the aim of seeing whether the system meets the requirements or not.
- f. Maintenance, maintaining the system so that it is in the best condition. At this step the maintenance process is carried out routinely so that the software continues to run and is maintained according to the best quality it should be.[6]

2.3 Arduino UNO

Arduino Uno is one of the products labeled arduino which is actually an electronic board that contains a microcontroller ATmega328 (a chip that functionally acts as a chip that functionally acts like a computer). This device can be used to realize electronic circuits from simple simple to complex.

3. RESULTS AND DISCUSSION

The results of this study are in the form of developing an information system for presenting prototype data for banknote nominal detectors, which functions to manage data from testing and data storage activities where it is hoped that data can be processed more easily. Where this system is only managed by the admin.

3.1. Interface implementation

3.1.1. Home page

This home page functions to display and access the home page of a website.

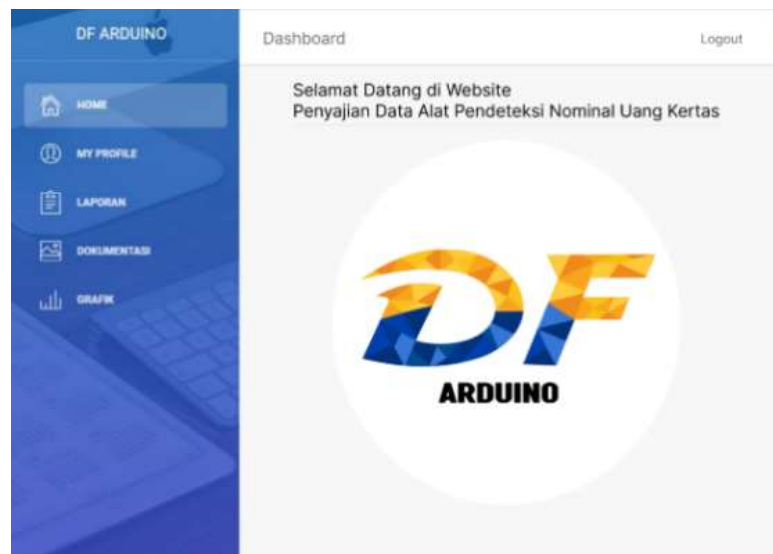

Figures 2 Homepage

3.1.2. Report Page

This report page is a page provided for admins to carry out the process of adding data, and printing reports. This page contains information based on prototype testing data.

Kesimpulan
 Dari data laporan pengujian di atas dapat disimpulkan bahwa uang kertas yang mudah dideteksi oleh DF Arduino adalah dengan urutan sebagai berikut.

No	Kondisi	Persentase Keberhasilan
1	Rapi	100%
2	Lencet	87%
3	Sekeh	50%
4	Warna Pudar	25%

Figures 3 Report Page

3.1.3. Graphics Pages

This graphic page is a page provided for admins to view graphs from testing prototypes of banknote nominal detectors which function to make data presentation easier to see.



Figures 4 Graph Pages

3.2. Display of Banknote Denomination Tool

The design results of the Prototype Detector Tool for Banknotes for the Blind, using the Arduino Uno microcontroller. This microcontroller will process the input data. This system works by receiving data from the color sensor by reading the value of the light intensity emitted by the super bright LED towards the object. If the nominal currency is placed above the color sensor. Data from this sensor is used to determine the RGB value of each currency. The results of this data are in the form of sound output issued by the speakers as information on the nominal value of money. The appearance of the banknote nominal detection device is presented from the outside of the prototype.



Figures 5 Exterior Prototypes

3.3. Overall Series

All components or hardware used in designing this prototype will be controlled or controlled by Arduino Uno R3.[7]The circuit of all components connected to Arduino Uno R3 can be seen in Figure 6.

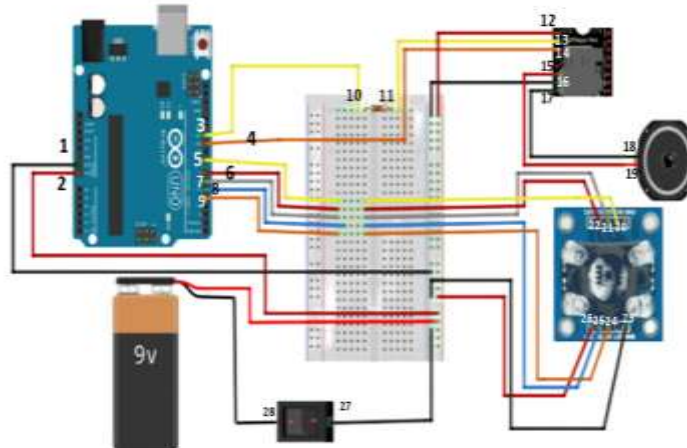

Figures 6 Overall System Circuits

3.4. Blackbox Testing

Testing the black box testing method is a test that observes the results of execution through test data and software functionality. The purpose of black box testing is to find out the weaknesses of the system so that the resulting data matches the data entered after the data is executed and minimizes errors in the application before it is used by the user. Where the result is that the design of a nominal banknote detector prototype can function as expected.[8]

3.5. RGB data retrieval process on banknotes

From the results of the tests that have been carried out, RGB data will be obtained which are used as boundaries to be able to distinguish each banknote. The basic colors consist of red, green, blue which when combined in a certain composition will produce various colors.[9]Each color has a different value and RGB code. The testing process uses several rupiah banknotes to obtain valid RGB data results.

Table 1 Result of RGB Value Range of Rupiah

Amount (IDR)	Red(R)	Green (G)	Blue (B)
100,000	47-54	59-68	47-53
50,000	63-70	49-56	37-40
20,000	51-56	48-50	41-43
10,000	60-67	59-66	39-45
5,000	42-50	54-56	41-46
2,000	45-51	44-50	34-41
1,000	51-57	46-57	45-48

3.6. Results of Testing the Design of Banknote Detection Devices for the Blind

Prototype design of banknote nominal detection devices (Arduino DF) can detect various banknote conditions such as banknotes that are neat, worn, wet, and faded in color. The following is explained in the table below.

Table 2 Nominal Testing of Neat Bills

Nominal	Total Experiment	detected	Undetected	%
1,000	10	8	2	80%
2,000	10	8	2	80%
5,000	10	10	0	100%
10,000	10	10	0	100%
20,000	10	10	0	100%
50,000	10	10	0	100%
100,000	10	10	0	100%
Average Percentage				94%

From the results of testing the tool using paper currency in neat conditions, it was obtained that the accuracy of data reading was 93% with 66 detections and 4 detections not.

Table 3 Nominal Testing of Scuffed Bills

Nominal	Total Experiment	detected	Undetected	%
1,000	10	7	3	70%
2,000	10	8	2	80%
5,000	10	7	3	70%
10,000	10	9	1	90%
20,000	10	10	0	100%
50,000	10	10	0	100%
100,000	10	10	0	100%
Average Percentage				87%

From the results of testing the tool using crumpled condition paper currency, it was found that the accuracy of data reading was 87% with 61 times detected and 9 not detected.

Table 4 Nominal Testing of Wet Bills

Nominal	Total Experiment	detected	Undetected	%
1,000	10	8	2	80%
2,000	10	7	3	70%
5,000	10	6	4	60%
10,000	10	7	3	70%
20,000	10	7	3	70%
50,000	10	8	2	80%
100,000	10	7	3	70%
Average Percentage				71%

From the results of testing the tool using paper currency under wet conditions, it was found that the accuracy of data reading was 71% of the 50 times it was detected and 20 times it was not detected.

Table 5 Nominal Testing of Faded Bills

Nominal	Total	detected	Undetected	%
---------	-------	----------	------------	---

Experiment				
1,000	10	5	5	50%
2,000	10	6	4	60%
5,000	10	4	6	40%
10,000	10	5	5	50%
20,000	10	4	6	40%
50,000	10	7	3	70%
100,000	10	6	4	60%
Average Percentage				53%

From the results of testing the tool using several types of paper currency with faded conditions, it was concluded that tests with faded conditions had a data reading accuracy of 53% from 37 detected and 33 undetected times. Based on the test results table above, the percentage of success in scanning banknotes from various banknotes is banknotes that are neat, worn, wet, and faded. So that it can be seen that the percentage of success from testing the nominal banknotes in neat condition is 94%, the crumpled condition is 87%, the wet condition is 71%, and the faded condition is 53%.

Based on research that was previously conducted by Widya Mentari, he made a tool for checking money for the visually impaired, namely Design and Development of a Microcontroller-Based Design of Authenticity and Currency Detection System for the Blind. can be used because of the limitations of the blind in seeing[10]. Based on previous research, it is necessary to design a simple system for the blind that uses color sensors in the system to detect the nominal value of banknotes. However, in the Prototype Design of a Banknote Detection Tool for the Blind, an innovation was made, namely adding speakers to the device to produce output in the form of sound from the detected nominal money. So that it is expected to make it easier for the blind in their daily activities, such as the activity of buying and selling goods and services

4. CONCLUSION

The nominal banknote detector prototype is capable of detecting rupiah currency according to the nominal entered, obtaining an accuracy value of 94% for banknotes in neat condition, 87% in muddy conditions, 71% in wet conditions, and 53% in faded color conditions. As well as the development of a data presentation system in the form of a dashboard can assist the admin in managing data from testing activities more easily, and so that data can be stored more systematically. It is hoped that for the next design, the esp-wifi component will be added to the prototype so that the integration between the data presentation website and the prototype can run in real-time.

ACKNOWLEDGEMENTS

Thanks to all parties who have supported this research so that it can be completed properly. specifically for the team involved in this research so they can complete it. I thank you very much.

REFERENCES

- [1] A. Farisi and H. Saputra, "Analysis of the Quality of Information Systems Using the McCall Method: A Case Study of SPON MDP," *Techno. Com*, vol. 21, no. 2, pp. 237–248, 2022, doi: 10.33633/tc.v21i2.5970.
- [2] A. Suhari Camara M, K. Aelani, and F. Dwi Juniari S, "Testing Website Quality using the McCall Software Quality Method," *J. Inf. Technol.*, vol. 3, no. 1, pp. 25–32, 2021, doi: 10.47292/joint.v3i1.43.
- [3] WW Abdul, "Analysis of Factors Affecting Employee Work Productivity in the Procurement Bureau," *Anal. fact. What Affects Product. Employee Work at the Procurement Bureau*, vol. 19, no. 1, 2019.
- [4] Z. Amri, MZ Uska, and BDD Arianti, "Usability Analysis of Hamzanwadi University Website on User Satisfaction Using the User Satisfaction Model," *EDUMATIC J. Educators. inform.*, vol. 2, no. 1, p. 15, 2018, doi: 10.29408/edumatic.v2i1.842.
- [5] H. Handayani, KU Faizah, AM Ayulya, M. Fikri, D. Wulan, and ML Hamzah, "Designing a Web-Based Goods Inventory Information System Using the Agile Software Development Method," *J. Test. and System Implementation. inf.*, vol. 1, no. 1, pp. 29–40, 2023, [Online]. Available: <http://journal.al-matani.com/index.php/jtisi/article/view/324>
- [6] N. Lutfiani, P. Harahap, Q. Aini, A. Dimas, AR Ahmad, and U. Rahardja, "I-Learning Project Management Innovation Using the Agile Scrumban Method," *InfoTekJar J. Nas. inform. and Technol. Jar.*, vol. 5, no. 1, pp. 96–101, 2020.
- [7] PES Dita, A. Al Fahrezi, P. Prasetyawan, and A. Amarudin, "Door Security System Using Arduino UNO R3 Microcontroller Based Fingerprint Sensor," *J. Tek. and Sist. computer.*, vol. 2, no. 1, pp. 121–135, 2021, doi: 10.33365/jtikom.v2i1.111.
- [8] AP Zanofa, R. Arrahman, M. Bakri, and A. Budiman, "Arduino Uno R3 Microcontroller Based Automatic Gate," *J. Tek. and Sist. computer.*, vol. 1, no. 1, pp. 22–27, 2020, doi: 10.33365/jtikom.v1i1.76.
- [9] L. Kurniawati, SK Risandriya, and H. Wijanarko, "Banknote Detectors for the Blind Using Neural Networks," *J. Appl. electr. Eng.*, vol. 3, no. 2, pp. 39–43, 2019, doi: 10.30871/jaee.v3i2.1821.