



E-ISSN : 2988-585X

JESII (Journal Elektronik Sistem Informasi)

UNIVERSITAS KEBANGSAAN REPUBLIK INDONESIA

Design of home control system prototype using Arduino uno microcontroller based on smartphone

Agriana Eka Putra¹, Nana Suryana²

^{1,2}Department of Information System, Univ. Kebangsaan Republik Indonesia, Indonesia

Article Info

Article history:

Received Jun 15, 23

Revised Jun 21, 23

Accepted Jun 29, 23

Keywords:

Information Technology

Smart Home

Arduino Uno

App Inventor

ABSTRACT

Many facilities are designed automatically to help and facilitate human activities in managing the environment or room of the house in order to increase comfort, efficiency, and tighter security. And, if you want to avoid crime such as theft, robbery, and other criminal acts, as well as other calamities such as fire that can not be predicted by us. Based on these problems, of course it needs a control system that is able to help and facilitate human activities in managing and managing a house without having to do it manually or can be called an automatic home. Such as an automatic door lock tool, turn on the electric socket, turn on the lights automatically and the home security system and can also detect fires automatically. Which can be combined with mobile or smartphone technology. This information system development design uses the Object Orieinted approach and the Prototyping development method. Meanwhile, the application of the control system prototype uses an arduino uno microcontroller that uses the C programming language and App Inventor. From the results of testing this prototype is expected to help solve the problems faced by homes today.

Corresponding Author:

Agriana Eka Putra,

Information System Department, Faculty of Computer Science and Information Systems,
Univ. Kebangsaan Republik Indonesia.

Jln. Terusan Halimun No.37 (Pelajar Pejuang 45) Bandung, Jawa Barat, Indonesia. 40614

Email: jesii@ukri.ac.id

1. INTRODUCTION

In this era, the whole world development provides positive value in various fields such as technology and information systems, both of them are very much required in various sectors of life, to support the performance of these sectors, one of them is the aspect of managing the physical environment or house room to increase comfort, efficiency, and tighter security so that the house is more peaceful[1]. Also, if you want to avoid such as theft, robbery, and other criminal acts, as well as other disasters such as fires that we can't predict. Rapid technological advancements enable the creation of numerous initiatives aimed at bringing convenience and comfort to people. One method is the creation of a system that may be used in the context of a home gate, specifically one that opens gates automatically with help from an Android system. Because it is easily accessible via Android, it is anticipated that this technology would streamline the application user experience and offer time efficiency.[2][3]

Technology advances and information systems participate to assist in the development of reliable system prototypes. To make our homes proper to be called automatic homes, of course, the tools and the applications that can be used to prototype systems in the house are very varied [4], for example, door locks, turning on home sockets, turning on lights, and detecting fire automatically. In addition, the advanced technology is also supported by mobile or smartphone technology which can be combined with the world of electronics so the functional system is more sophisticated and modern [5][6]. Therefore, it is necessary to have an information system technology tool that is capable of helping facilitate human activities, so they can manage the physical environment of the house and help make it easier to control the house safer and more comfortably. The objective is to increase the comfort, efficiency, and security of our homes with used voice commands on a smartphone as a form of convenience and security, or we can call as an automatic home.

2. METHOD

2.1 System Approach Method

The systems approach method that the author uses is Object Oriented and UML (Unified Modeling Language) Tools, consisting of Use Case Diagrams, Sequence Diagrams, and Activity Diagrams [7]. Programmin C language with to practice with micro controller, One may describe the Arduino Uno as an open-source platform for physical computing. Arduino is more than simply a tool for developers. With the addition of specific components, this tool can be used for remote monitoring over the internet using devices like smartphones. Arduino is a combination of hardware, a programming language, and a sophisticated integrated development environment (IDE). [2] The inputs and outputs on Arduino microcontrollers can be used to obtain information, and Arduino can provide output based on the information it receives. Using HTTP requests, Arduino microcontrollers may also transmit and receive data over the internet. Esp board is a straightforward microcontroller that may be linked to the internet. Either ESP microcontrollers can be used as a Wi-Fi server or they can connect to one. [3] When utilizing a USB cable to upload new code to the Arduino board, another use for it is possible. With the help of the Arduino IDE, users can create programs for the Arduino platform using the C or C++ programming languages on nearly any personal computer. Market vendors offer a wide variety of Arduino microcontroller boards. Little research is needed in order to use the appropriate Arduino board for the project. Each Arduino board has unique features and characteristics. [8]

2.2 System Development Method

While the system development method that the author chose is using the Prototyping model because this method determines the output or input of data on a screen or report. Prototyping is usually shown to the user before the actual system is finished, to ensure that the system meets the user's needs. This prototyping tool is commonly used to create an interface to a system [9][10].

1. Identified User Requirements

At this stage, system analysis will carry out a feasibility study and a study of user needs, involving the interface model, procedural techniques and the technology to be used. This research will use a microcontroller on Arduino Uno that will later identify code using C as its programming language.

2. Prototype Implementation

At this stage, system analysis collaborates with system prototype development programming to show the customer the modeling system to be built.

3. Prototype Tested

At this stage, system analysis shows to the customer the system model that was built.

4. Prototype Determine

Whether acceptable to the customer or user. System analysis at this stage will detect and identify the extent to which of modeling made can be accepted by the customer or even have to completely overhaul.

5. Prototype Changed

At this stage, the system collaborates again with programming to improve the prototype modeling, it makes into a system that can be accepted by the customer or user.

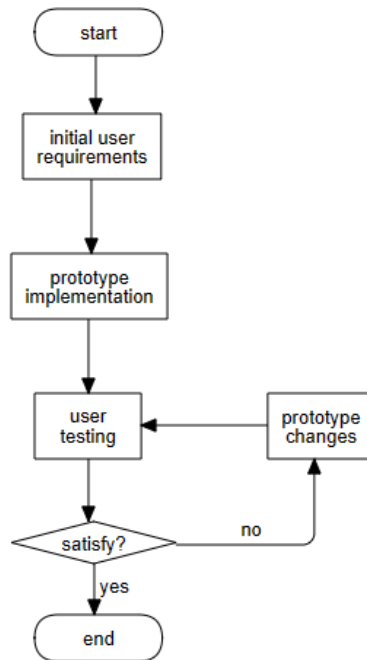

Figure 1. Prototype Stages

2.3 System Recommendation

Based on the result of an analysis of the current system, there are still many deficiencies, after knowing the current system, it can be concluded that:

Table 1. System recommendations

No	Old System	New System
1	The process of controlling the house is still manual	with the design of this control system, it can be easier to carry out activities inside and outside the home.
2	No fire detection equipment	can detect when a fire occurs

3. RESULT AND DISCUSSION

3.1. System Design

System design is the analysis stage of the system development cycle which is defined from functional requirements and preparations for designing implementations describe how a system is formed which can be in the form of depiction, design, and sketching or arrangement of several separate elements into a unified whole, including regarding configuration of the hardware and software components of a system.

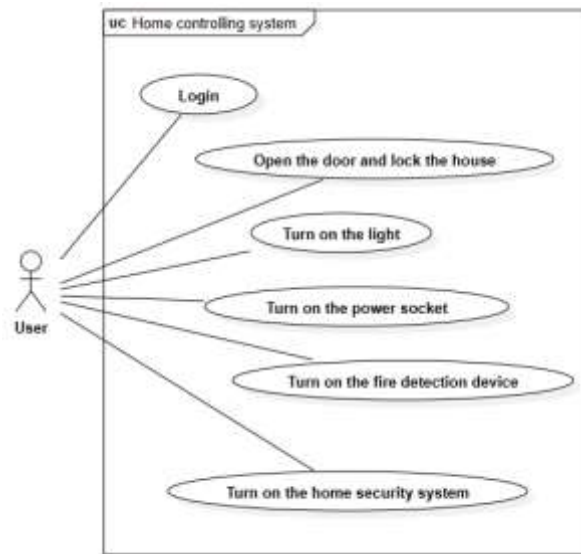

Figure 2. Usecase Diagram

The system built consists of one actor called the user, who serves as a controller and also has access rights to input data to application output.

The process for controlling is shown then in the form of an Activity Diagram below:

1. Login Activity Diagram

Login Activity Diagram is a diagram that gives an overview of how the login process occurs. The diagram follows as:

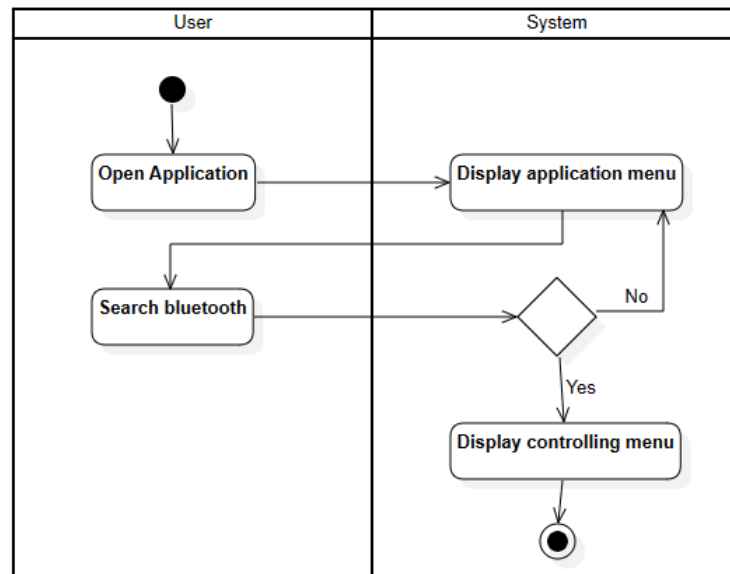

Figure 3. Login Activity Diagram

2. Home Security System Activity Diagram

Home Security System Activity Diagram is a diagram that gives an overview of how the security system occurs. The diagram follows as:

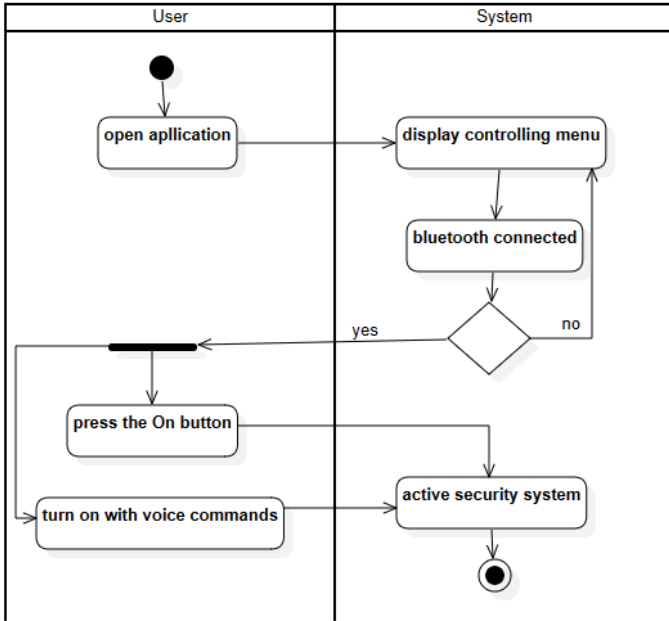

Figure 4. Turning on the security home activity diagram

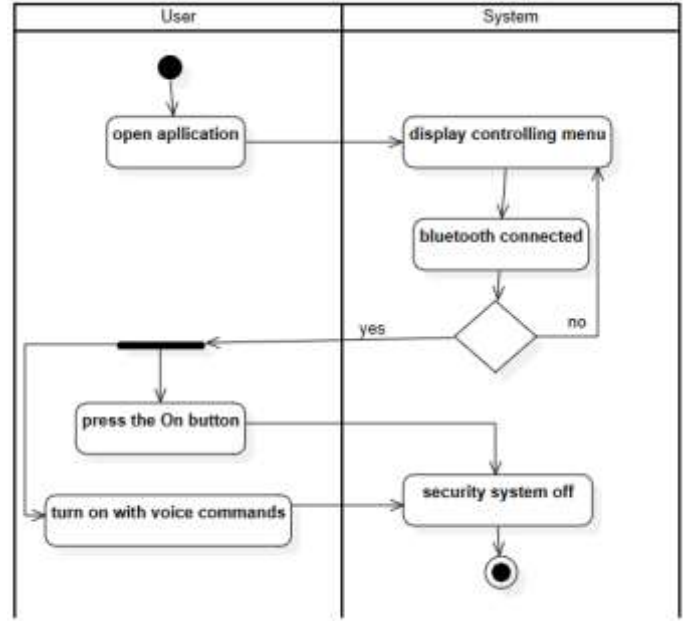

Figure 5. Turning off the security home activity diagram

3. Portal Activity Diagram

Portal Activity Diagram is a diagram that gives an overview of how the process of opening and closing doors in the prototype design is made. The diagram follows as:

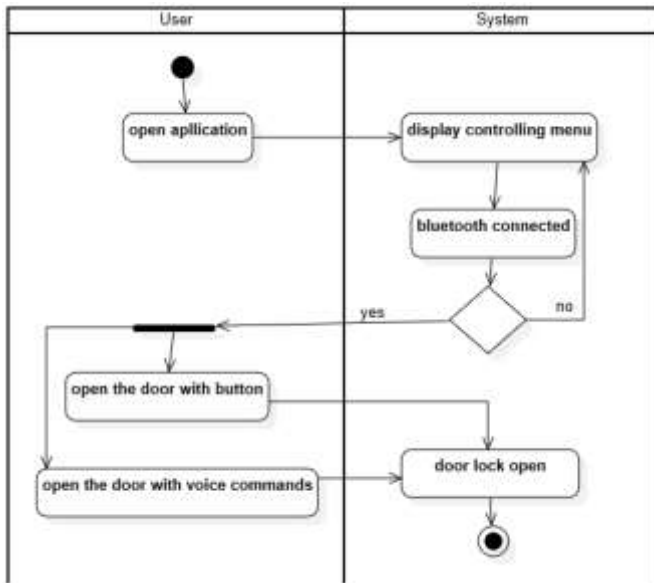

Figure 6. Open the door activity diagram

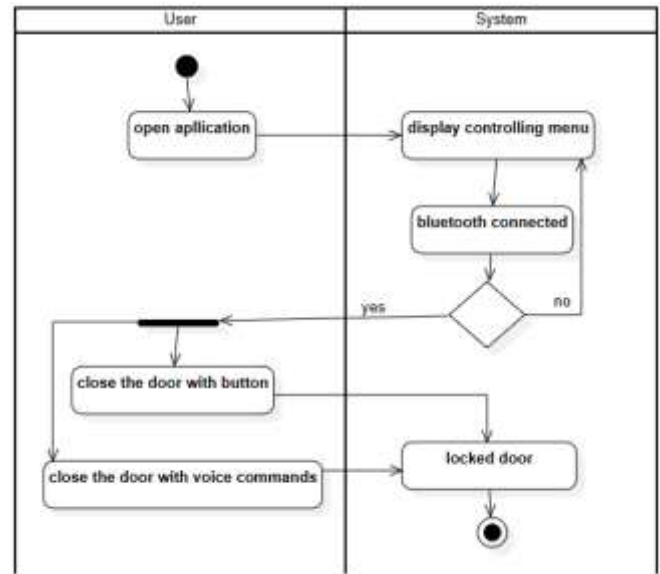

Figure 7. Close the door activity diagram

4. Fire Detector Activity Diagram

The Fire Detector Activity Diagram is a diagram that gives an overview of how the process of detecting fires on a prototype home control system. The diagram follows as:

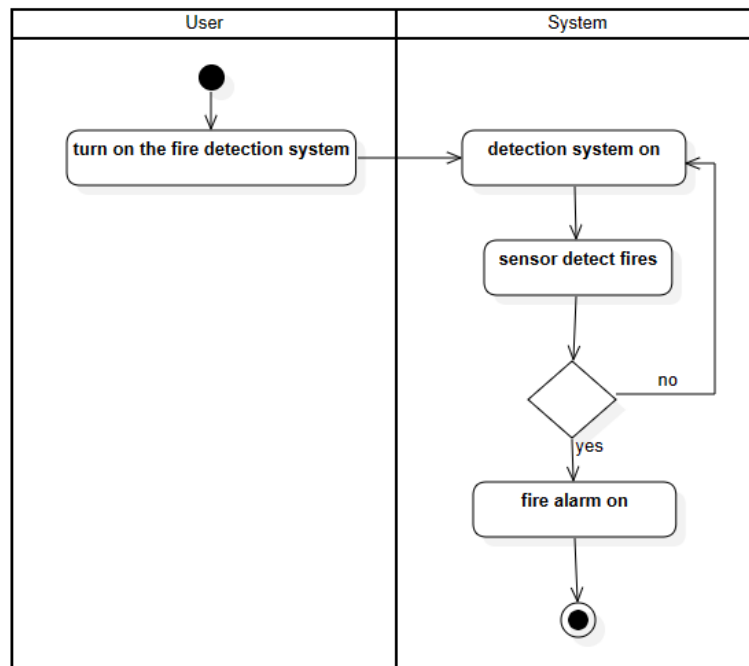

Figure 8. Fire detection activity diagram

5. Switch Lights Activity Diagram

Switch Lights Activity Diagram for the head of the branch is a diagram of the proses of turning on and turning off the lights. The diagram follows as:

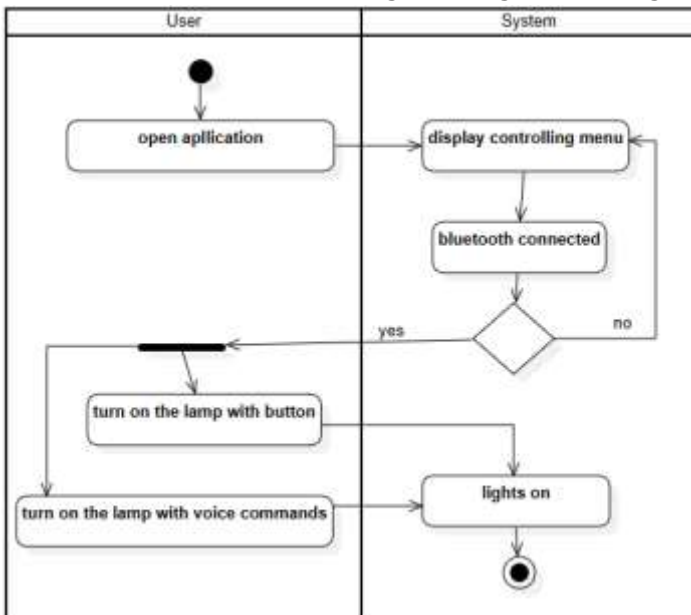

Figure 9. Light on activity diagram

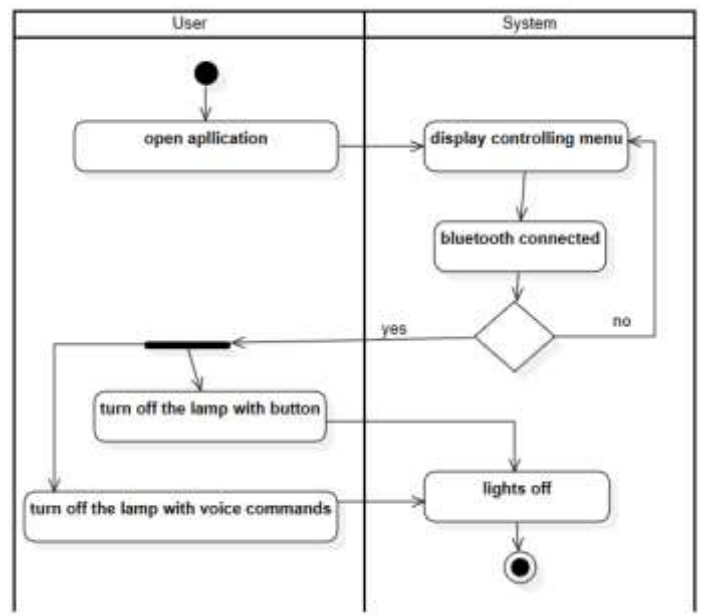

Figure 10. Light off activity diagram

6. Socket Activity Diagram

Socket Activity Diagram is a diagram of the process of turning on and turning off the socket. The diagram follows as:

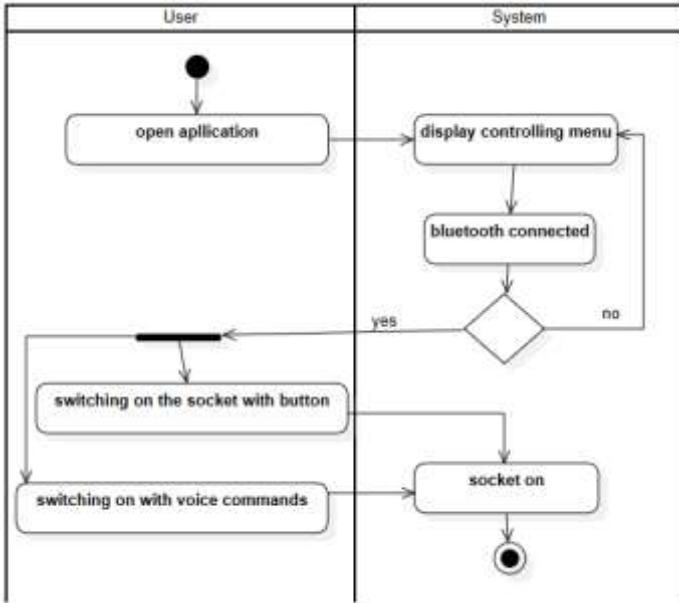

Figure 11. Socket on activity diagram

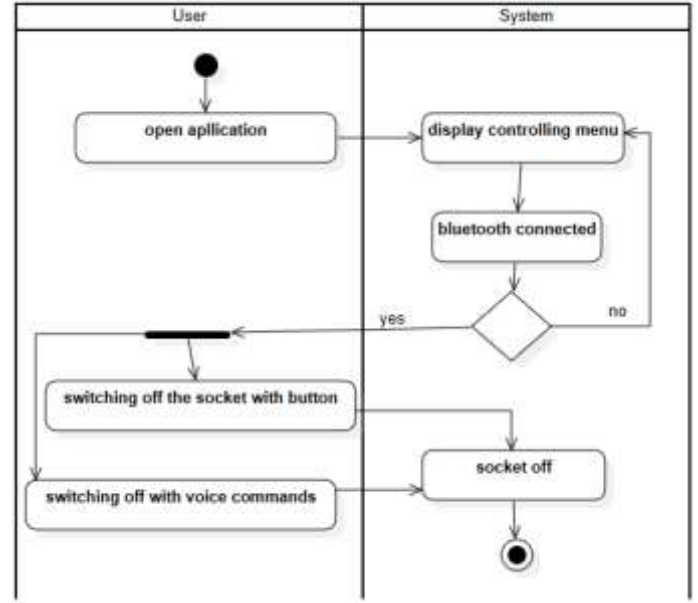

Figure 12. Socket off activity diagram

The Sequence Diagram describes the interactions between objects in sequential order i.e the order in which these interactions take place, sequence diagram of the running system is shown in the picture below:

1. Login Sequence Diagram

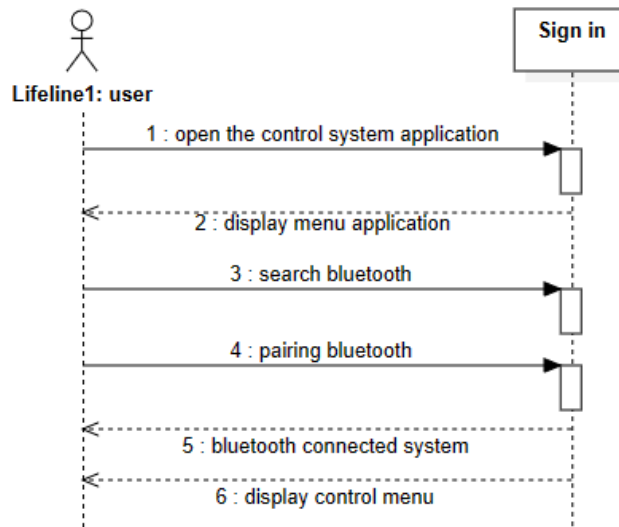

Figure 13. Login sequence diagram

2. Security System Sequence Diagram

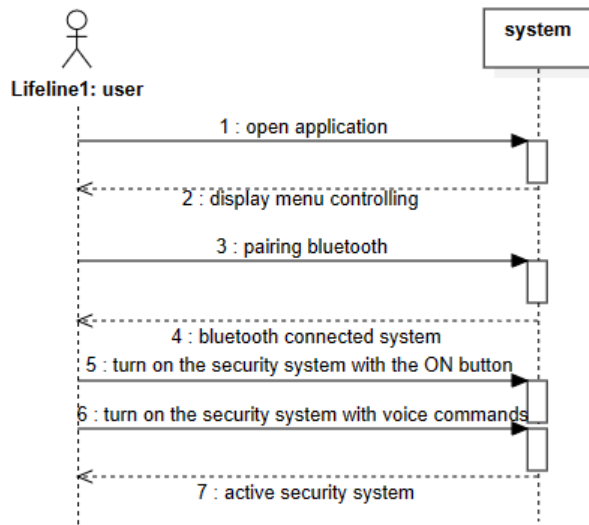

Figure 14. Turn on security system sequence diagram

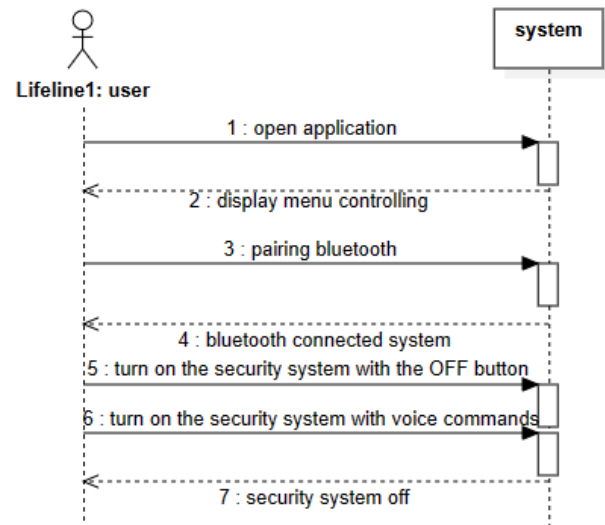

Figure 15. Turn off security system sequence diagram

3. Portal Sequence Diagram

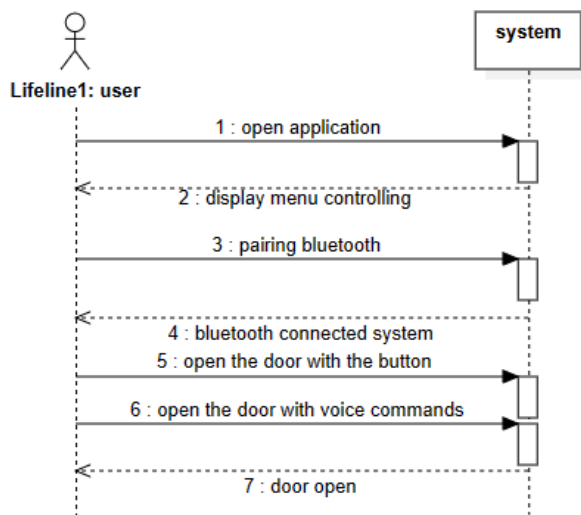

Figure 16. Open the door sequence diagram

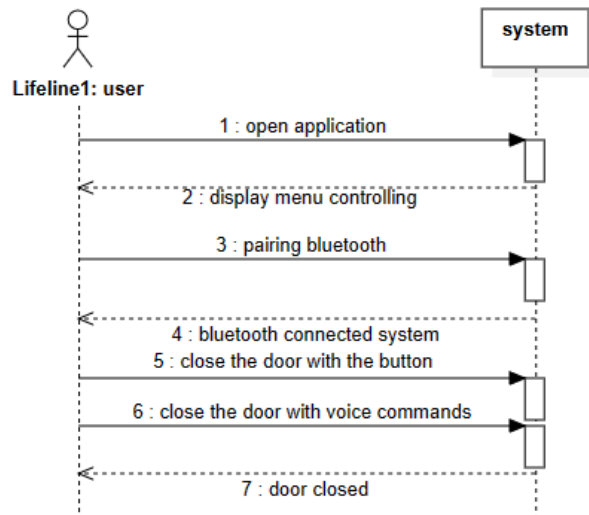

Figure 17. Close the door sequence diagram

4. Fire Detection Sequence Diagram

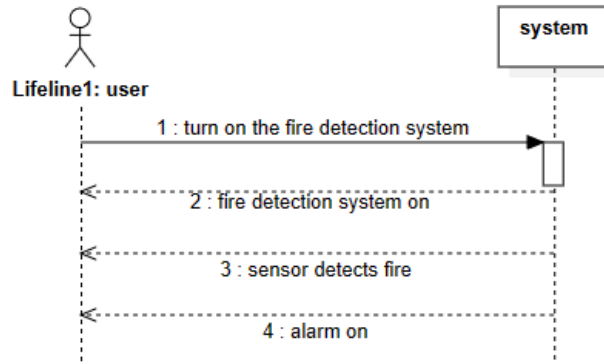

Figure 18. Fire detection system sequence diagram

5. Lighting System Sequence Diagram

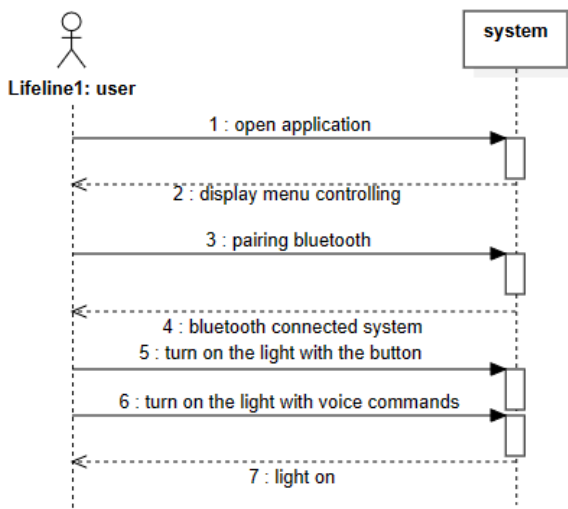

Figure 19. Light on sequence diagram

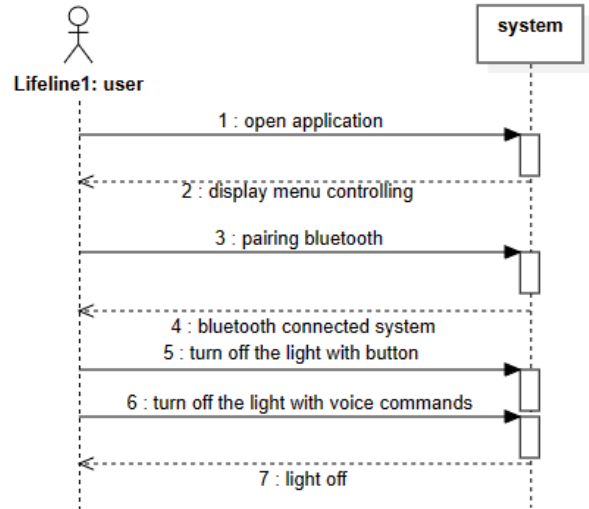

Figure 20. Light off sequence diagram

6. Socket System Sequence Diagram

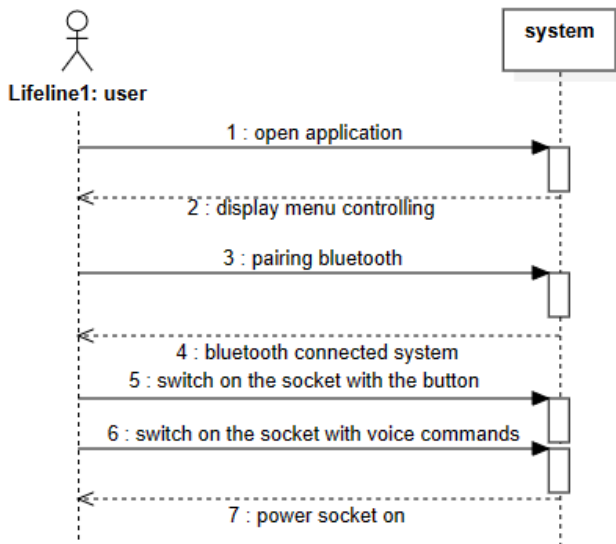

Figure 21. Socket on sequence diagram

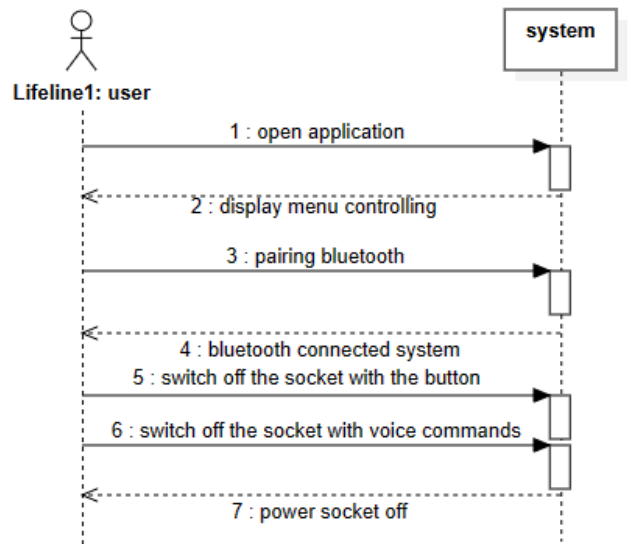

Figure 22. Socket off sequence diagram

3.2. Result of Planning System

The interface design is an overview of the system created based on the previous design. The design of the interface includes two things are the main page and the overall design of the prototype built.

3.2.1. Main Page



Figure 23. Interface main page

This main page is the main view in the controller system application. This main page is the main view of the controller system application.

3.2.2. Prototype Circuit

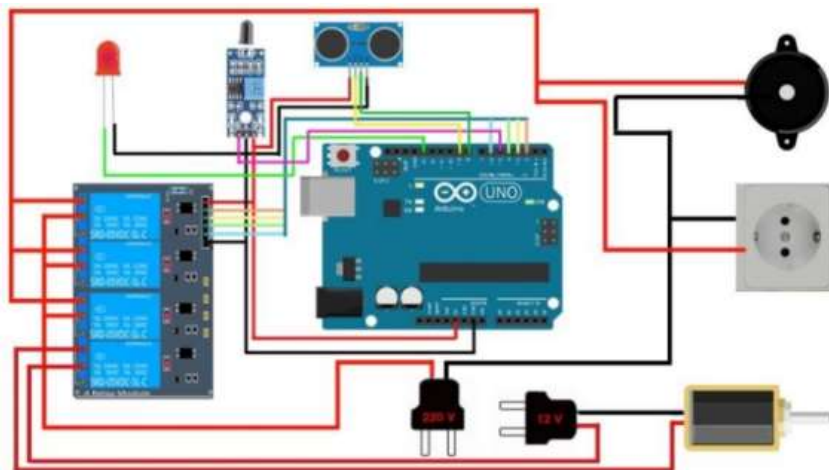

Figure 24. Prototype circuit design

This whole prototype circuit is made in order to understand how all the current paths of all circuit work. The Arduino development board is the type of hardware that Arduino employs. The Arduino IDE

(Integrated Development Environment) is the name of the software used by Arduino to create code. These microcontrollers, which come equipped with an 8-bit Atmel AVR or a 32-bit Atmel ARM, can be readily programmed using the C or C++ language in the Arduino IDE. The Arduino microcontroller was initially created for experts and students to create gadgets that can communicate with their surroundings via sensors.

4. CONCLUSION

Based on the results of the analysis and discussion of the system in the previous chapters, it can be concluded that the design of a prototype home control system using a smartphone-based arduino uno microcontroller produces:

1. With this control system, it can facilitate the activities of homeowners to be able to control the physical environment in their homes.
2. Make homeowners feel comfortable and safe. And The system built has been equipped with very varied tools

ACKNOWLEDGEMENTS

Thank you to all parties who have supported this research so that it can be completed properly. Especially, for the parents who have always supported and guided me in this research. I'm very grateful.

REFERENCES

- [1] Mukhsin, "Peranan Teknologi Informasi dan Komunikasi dalam Kurikulum 2013," *J. Pendidik. Penabur*, vol. No.21/Tahu, no. 77-78, pp. 1-8, 2019.
- [2] Rosdiana, A. Hasibuan, and D. Sartika Tambunan, "Design and Development of An Automatic Door Gate Based on Internet of Things Using Arduino Uno Internet of Things IoT Arduino Automatic Door Gate Bluetooth," *Bull. Comput. Sci. Electr. Eng.*, vol. 2, no. 1, pp. 17-27, 2021, doi: 10.25008/bcsee.v2i1.1141.
- [3] A. S. Ismailov and Z. B. Jo'rayev, "Study of arduino microcontroller board," *Sci. Educ. Sci. J.*, vol. 3, no. 3, pp. 172-179, 2022.
- [4] Y. M. P. Siregar, "Perancangan dan Pembuatan Sistem Keamanan Rumah Menggunakan SMS Gateway Berbasis Mikrokontroler Arduino Atmega 2560," Universitas Sumatera Utara, 2018.
- [5] Destiana, "Pengaruh teknologi informasi berbasis android (Smartphone) dalam pendidikan industry 4.0," *Pros. Semin. Nas. Pendidik. Progr. Pascasarj. Univ. PGRI Palembang*, pp. 190-197, 2019.
- [6] D. Susilo, C. Sari, and G. W. Krisna, "Sistem Kendali Lampu Pada Smart Home Berbasis IOT (Internet of Things)," *ELECTRA Electr. Eng. Artic.*, vol. 2, no. 1, p. 23, 2021, doi: 10.25273/electra.v2i1.10504.
- [7] Sholiq, *Pemodelan sistem informasi berorientasi objek dengan UML*. Yogyakarta: Graha Ilmu, 2006.
- [8] K. M. HamaRaouf and A. O. Abdulrahman, "Microcontroller-Based Kurdish Understandable and Readable Digital Smart Clock," *Sci. J. Univ. Zakho*, vol. 10, no. 1, pp. 1-4, 2022, doi: 10.25271/sjuoz.2022.10.1.870.
- [9] R. S. Pressman, *Rekayasa Perangkat Lunak (Pendekatan Praktisi)*, 7th ed. Yogyakarta: Andi Publisher, 2012.
- [10] J. Sarwono, *Metode penelitian kuantitatif & kualitatif*. Yogyakarta: Graha Ilmu, 2006.